

UNIT V -SIGNALGENERATOR & WAVE ANALYZERS

SIGNAL GENERATOR: Fixed And Variable Af Oscillators, Standard Signal Generator, Square Pulse, Random Noise And Sweep Generator- Principles Of Working (Block Diagram Approach)

ANALYZERS: Introduction, Basic Wave Analyzers, Frequency Selective Wave Analyzer, Heterodyne Wave Analyzer, Harmonic Distortion Analyzers, Spectrum Analyzers, And Digital Fourier Analyzer.

INTRODUCTION

A signal generator is an electronic device that generates repeating or non-repeating electronic signals in either the analog or the digital domain. It is generally used in designing, testing, troubleshooting, and repairing electronic or electroacoustic devices, though it often has artistic uses as well

DIFFERENCEBETWEENASIGNALGENERATORANDANOSCILLATOR

Signal generators are the sources of electrical signals used for the purpose of testing and Operating different kinds of electrical equipment. A signal generator provides different types of waveforms such as sine,triangular,square,pulse etc.,whereasanoscillatorprovidesonlysinusoidalsignalat the output.

TheAfoscillators aredivided into two types.Theyareasfollows

1. Fixed frequencyAF oscillator
2. Variable frequencyAF oscillator.

1. FixedFrequencyAF Oscillator

Many instrument circuits contain oscillator as one of its integral parts to provide output signal within the specified fixed audio frequency range. This specified audio frequency range can be 1 kHz signal or 400 Hz signal. The 1 kHz frequency signal is used to execute a bridge circuit and 400Hzfrequencysignalisusedforaudiotesting.AfixedfrequencyAFoscillatoremploysaniron coretransformer.Duetothisapositivefeedbackisobtainedthroughtheinductivecouplingplaced betweentheprimarywindingandsecondarywindingofthetransformerandhencefixedfrequency oscillations are generated.

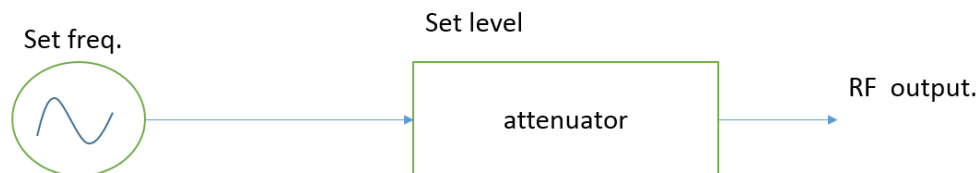

2. VariableFrequency AF Oscillator

Itisageneralpurposeoscillatorusedinlaboratory.Itgeneratesoscillationswithintheentireaudio frequencyrangei.e.From20Hzto20kHz.Thisoscillatorprovidesapure,constantsine wave

output throughout this af range. The examples of variable af oscillators used in laboratory are rc feedback oscillator, beat frequency oscillator.

STANDARD SIGNAL GENERATOR:

A standard signal generator produces known and controllable voltages. It is used as power source for the measurement of gain, signal to noise ratio (S/N), bandwidth, standing wave ratio and other properties. It is extensively used in the testing of radio receivers and transmitters.

The instrument is provided with a means of modulating the carrier frequency, which is indicated by the dial setting on the front panel. The modulation is indicated by a meter. The output signal can be Amplitude Modulated (AM) or Frequency Modulated (FM). Modulation may be done by a sine wave, square wave, triangular wave or a pulse. The elements of a conventional signal generator are shown in Fig. 8.2 (a).

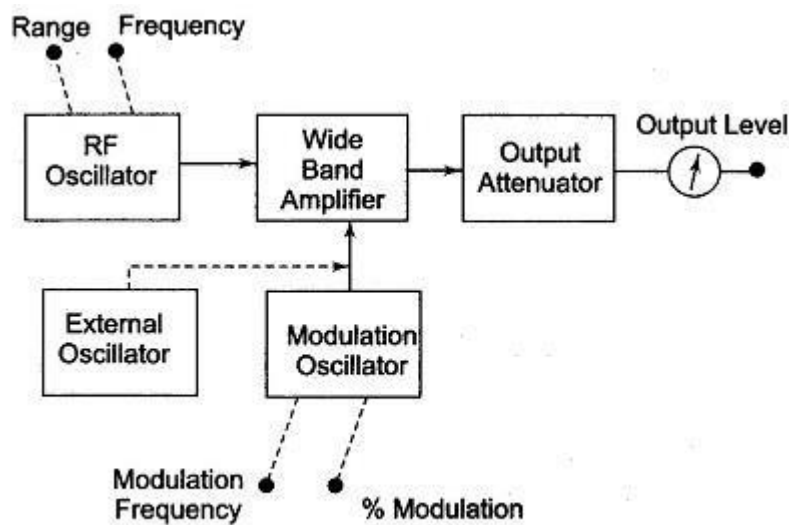

Fig. 8.2 (a) Conventional Standard Signal Generator

The carrier frequency is generated by a very stable RF oscillator using an LC tank circuit, having a constant output over any frequency range. The frequency of oscillations is indicated by the frequency range control and the vernier dial setting. AM is provided by an internal sine wave generator or from an external source.

(Modulation is done in the output amplifier circuit. This amplifier delivers its output, that is, modulation carrier, to an attenuator. The output voltage is read by an output meter and the attenuator output setting.)

Frequency stability is limited by the LC tank circuit design of the master oscillator. Since range switching is usually accomplished by selecting appropriate capacitors, any change in frequency range upset the circuit design to some extent and the instrument must be given time to stabilise at the new resonant frequency.

In high frequency oscillators, it is essential to isolate the oscillator circuit from the output circuit. This isolation is necessary, so that changes occurring in the output circuit do not affect

the oscillator frequency, amplitude and distortion characteristics. Buffer amplifiers are used for this purpose.

SQUARE AND PULSE GENERATOR BLOCK DIAGRAM (LABORATORY TYPE):

Square and Pulse Generator Block Diagram are used as measuring devices in combination with a CRO. They provide both quantitative and qualitative information of the system under test. They are made use of in transient response testing of amplifiers. The fundamental difference between a pulse generator and a square wave generator is in the duty cycle.

$$\text{Duty cycle} = \frac{\text{pulse width}}{\text{pulse period}}$$

A square wave generator has a 50% duty cycle.

Requirements of a Pulse

The pulse should have minimum distortion, so that any distortion, in the display is solely due to the circuit under test.

The basic characteristics of the pulse are rise time, overshoot, ringing, sag, and undershoot.

The pulse should have sufficient maximum amplitude, if appreciable output power is required by the test circuit, e.g. for magnetic core. At the same time, the attenuation range should be adequate to produce small amplitude pulses to prevent over driving of some test circuit.

The range of frequency control of the pulse repetition rate (PRR) should meet the needs of the experiment. For example, a repetition frequency of 100 MHz is required for testing fast circuits. Other generators have a pulse-burst feature which allows a train of pulses rather than a continuous

Some pulse generators can be triggered by an externally applied trigger signal; conversely, pulse generators can be used to produce trigger signals, when this output is passed through a differentiator circuit.

The output impedance of the pulse generator is another important in a fast pulse system, the generator should be matched to the cable and the cable to the test circuit. A mismatch would cause energy to be reflected back to the generator by the test circuit, and this may be re-reflected by the generator, causing distortion of the pulses.

DC coupling of the output circuit is needed, when dc bias level is to be maintained.

The basic circuit for pulse generation is the asymmetrical multi-vibrator. A laboratory type square wave and pulse generator is shown in Fig. 8.6.

The frequency range of the instrument is covered in seven decade steps from 1 Hz to 10 MHz, with a linearly calibrated dial for continuous adjustment on all ranges.

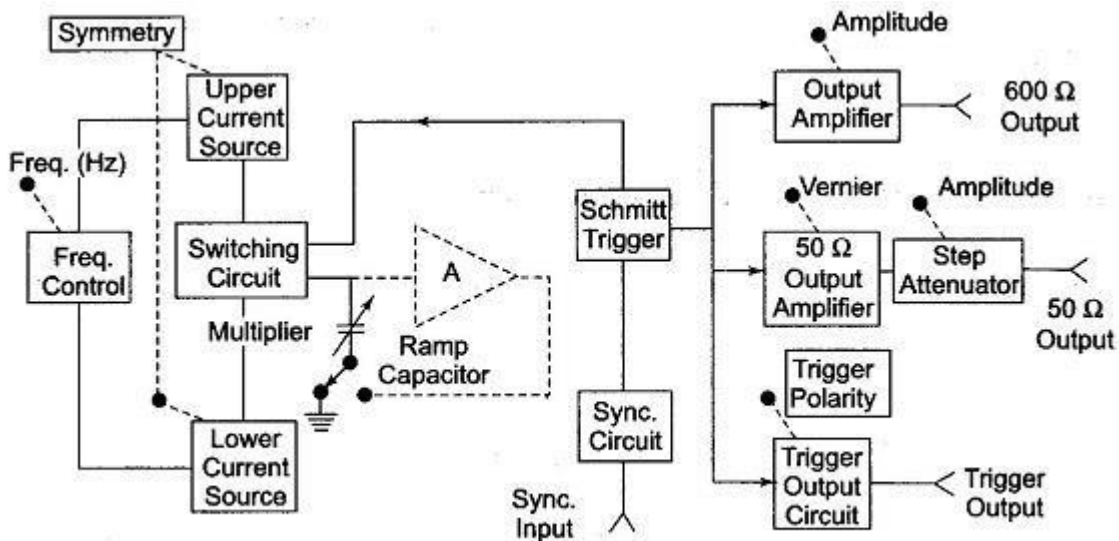

Fig. 8.6 Block Diagram of a Pulse Generator

The duty cycle can be varied from 25–75%. Two independent outputs are available, a 50 Ω source that supplies pulses with a rise and fall time of 5 ns at 5 V peak amplitude and a 600 Ω source which supplies pulses with a rise and fall time of 70 ns at 30 V peak amplitude. The instrument can be operated as a free-running generator, or it can be synchronised with external signals.

The basic generating loop consists of the current sources, the ramp capacitor, the Schmitt trigger and the current switching circuit, as shown in Fig. 8.7.

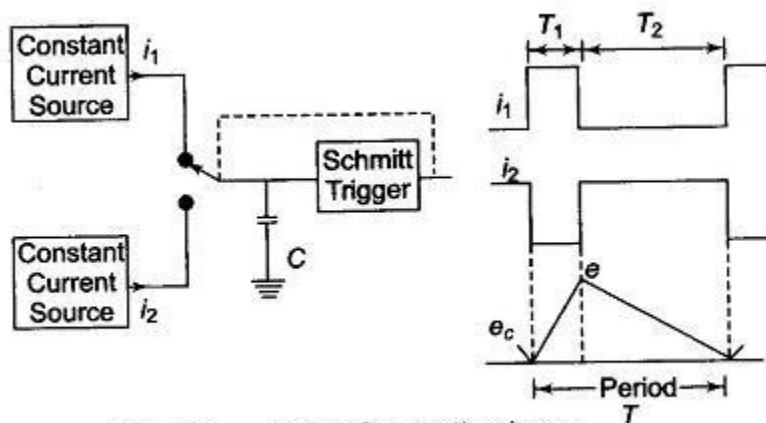

Fig. 8.7 Basic Generating Loop

The upper current source supplies a constant current to the capacitor and the capacitor voltage increases linearly. When the positive slope of the ramp voltage reaches the upper limit set by the internal circuit components, the Schmitt trigger changes state. The trigger circuit output becomes negative and reverses the condition of the current switch. The capacitor discharges linearly, controlled by the lower current source. When the negative ramp reaches a predetermined lower level, the Schmitt trigger switches back to its original state. The entire process is then repeated. The ratio i_1/i_2 determines the duty cycle, and is controlled by symmetry control. The sum of i_1 and i_2 determines the frequency. The size of the capacitor is selected by the multiplier switch.

The unit is powered by an internal supply that provides regulated voltages for all stages of the instrument.

Random Noise Generator Block Diagram:

A simplified Random Noise Generator Block Diagram used in the audio frequency range is shown in Fig. 8.8.

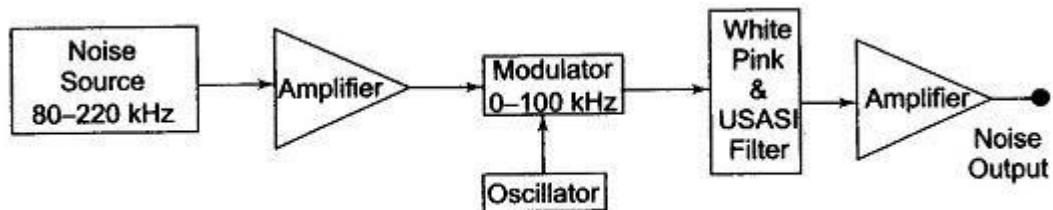

Fig. 8.8 Random Noise Generator

The instrument offers the possibility of using a single measurement to indicate performance over a wide frequency band, instead of many measurements at one frequency at a time. The spectrum of random noise covers all frequencies and is referred to as White noise, i.e. noise having equal power density at all frequencies (an analogy is white light). The power density spectrum tells us how the energy of a signal is distributed in frequency, but it does not specify the signal uniquely, nor does it tell us very much about how the amplitude of the signal varies with time. The spectrum does not specify the signal uniquely because it contains no phase information.

The method of generating noise is usually to use a semi conductor noise diode, which delivers frequencies in a band roughly extending from 80 — 220 kHz. The output from the noise diode is amplified and heterodyned down to the audio frequency band by means of a balanced symmetrical modulator. The filter arrangement controls the bandwidth and supplies an output signal in three spectrum choices, white noise, pink noise and Usasi noise.

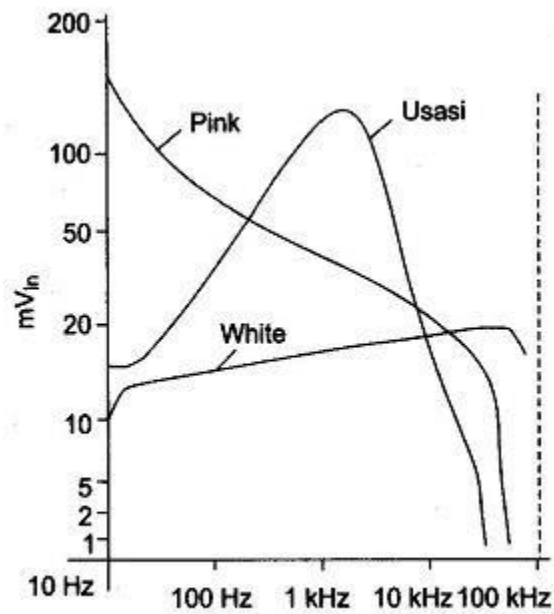

Fig. 8.9 Frequency Response

From Fig. 8.9, it is seen that white noise is flat from 20 Hz to 25 kHz and has an upper cutoff frequency of 50 kHz with a cutoff slope of -12 db/octave.

Pink noise is so called because the lower frequencies have a larger amplitude, similar to red light. Pink noise has a voltage spectrum which is inversely proportional to the square root of frequency and is used in bandwidth analysis.

Usasi noise ranges simulate the energy distribution of speech and music frequencies and is used for testing audio amplifiers and loud speakers.

SWEEP GENERATOR:

Block Diagram of Sweep Generator – It provides a sinusoidal output voltage whose frequency varies smoothly and continuously over an entire frequency band, usually at an audio rate. The process of frequency modulation may be accomplished electronically or mechanically.

It is done electronically by using the modulating voltage to vary the reactance of the oscillator tank circuit component, and mechanically by means of a motor driven capacitor, as provided for in a modern laboratory type signal generator. Figure 8.10 shows a basic block diagram of a sweep generator.

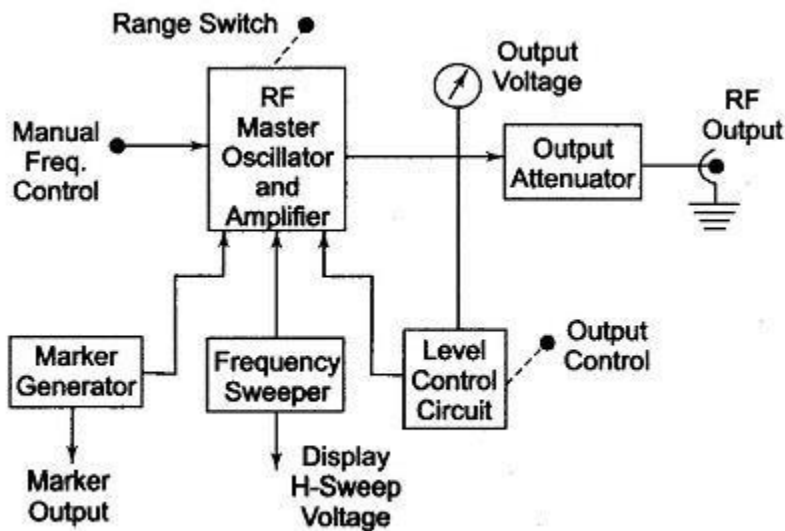

Fig. 8.10 Sweep Generator

The frequency sweeper provides a variable modulating voltage which causes the capacitance of the master oscillator to vary. A representative sweep rate could be of the order of 20 sweeps/second. A manual control allows independent adjustment of the oscillator resonant frequency.

The frequency sweeper provides a varying sweep voltage for synchronisation to drive the horizontal deflection plates of the CRO. Thus the amplitude of the response of a test device will be locked and displayed on the screen.

To identify a frequency interval, a marker generator provides half sinusoidal waveforms at any frequency within the sweep range. The marker voltage can be added to the sweep voltage of the CRO during alternate cycles of the sweep voltage, and appears superimposed on the response curve.

The automatic level control circuit is a closed loop feedback system which monitors the RF level at some point in the measurement system. This circuit holds the power delivered to the load or test circuit constant and independent of frequency and impedance changes. A constant power level prevents any source mismatch and also provides a constant readout calibration with frequency.

Wave Analyzer:

Introduction : It can be shown mathematically that any complex waveform is made up of a fundamental and its harmonics.

It is often desired to measure the amplitude of each harmonic or fundamental individually. This can be performed by instruments called wave analyzers. This is the simplest form of analysis in the frequency domain, and can be performed with a set of tuned filters and a voltmeter. Wave analyzers are also referred to as frequency selective voltmeters, carrier frequency voltmeters, and selective level voltmeters. The instrument is tuned to the frequency of one component whose amplitude is measured.

This instrument is a narrow band superheterodyne receiver, similar to a spectrum analyzer (discussed later). It has a very narrow pass-band. A meter is used for measurement, instead of a CRT. Wave analyzers are used in the low RF range, below 50 MHz and down through the AF range. They provide a very high frequency resolution.

Some wave analyzers have the facility of automatic frequency control, in which the tuning automatically locks to a signal. This makes it possible to measure the amplitude of signals that are drifting in frequency by amounts that would carry them outside the widest pass-band available.

Basic Wave Analyzer

A basic wave analyzer is shown in Fig. 9.1(a). It consists of a primary detector, which is a simple LC circuit. This LC circuit is adjusted for resonance at the frequency of the particular harmonic component to be measured.

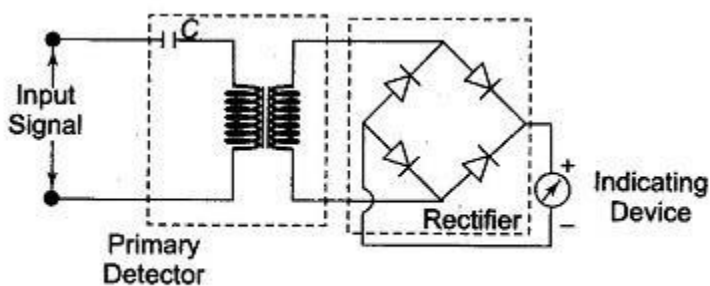

Fig. 9.1 (a) Basic Wave Analyzer

The intermediate stage is a full wave rectifier, to obtain the average value of the input signal. The indicating device is a simple dc voltmeter that is calibrated to read the peak value of the sinusoidal input voltage.

Since the LC circuit is tuned to a single frequency, it passes only the frequency to which it is tuned and rejects all other frequencies. A number of tuned filters, connected to the indicating device through a selector switch, would be required for a useful Wave analyzer.

Heterodyne Wave Analyzer:

Wave analyzers are useful for measurement in the audio frequency range only. For measurements in the RF range and above (MHz range), an ordinary wave analyzer cannot be used. Hence, special types of wave analyzers working on the principle of heterodyning (mixing) are used. These wave analyzers are known as Heterodyne Wave Analyzer.

In this wave analyzer, the input signal to be analyzed is heterodyned with the signal from the internal tunable local oscillator in the mixer stage to produce a higher IF frequency.

By tuning the local oscillator frequency, various signal frequency components can be shifted within the pass-band of the IF amplifier. The output of the IF amplifier is rectified and applied to the meter circuit.

An instrument that involves the principle of heterodyning is the Heterodyning tuned voltmeter, shown in Fig. 9.3.

The input signal is heterodyned to the known IF by means of a tunable local oscillator. The amplitude of the unknown component is indicated by the VTVM or output meter. The VTVM is calibrated by means of signals of known amplitude..

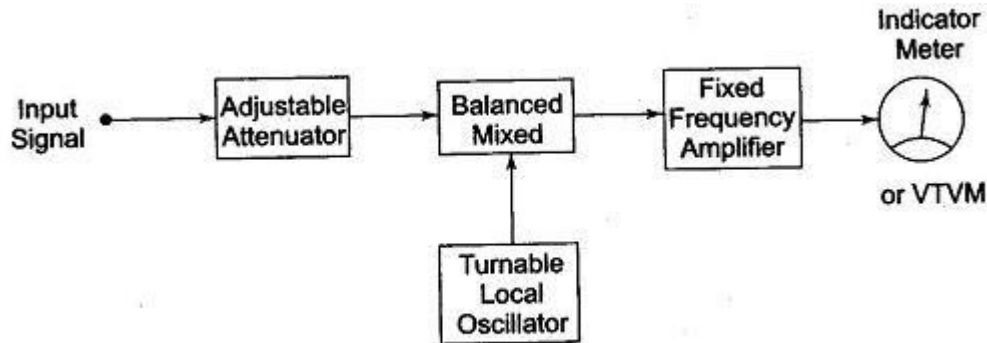

Fig. 9.3 Heterodyne Wave Analyzer

The frequency of the component is identified by the local oscillator frequency, i.e. the local oscillator frequency is varied so that all the components can be identified. The local oscillator can also be calibrated using input signals of known frequency. The fixed frequency amplifier is a multistage amplifier which can be designed conveniently because of its frequency characteristics. This analyzer has good frequency resolution and can measure the entire AF frequency range. With the use of a suitable attenuator, a wide range of voltage amplitudes can be covered. Their disadvantage is the occurrence of spurious cross-modulation products, setting a lower limit to the amplitude that can be measured.

Two types of selective amplifiers find use in Heterodyne wave analyzers. The first type employs a crystal filter, typically having a centre frequency of 50 kHz. By employing two crystals in a band-pass arrangement, it is possible to obtain a relatively flat pass-band over a 4 cycle range. Another type uses a resonant circuit in which the effective Q has been made high and is controlled by negative feedback. The resultant signal is passed through a highly selective 3-section quartz crystal filter and its amplitude measured on a Q-meter.

When a knowledge of the individual amplitudes of the component frequency is desired, a heterodyne wave analyzer is used.

A modified heterodyne wave analyzer is shown in Fig. 9.4. In this analyzer, the attenuator provides the required input signal for heterodyning in the first mixer stage, with the signal from a local oscillator having a frequency of 30 —48 MHz.

The first mixer stage produces an output which is the difference of the local oscillator frequency and the input signal, to produce an IF signal of 30 MHz. This IF frequency is uniformly amplified by the IF amplifier. This amplified IF signal is fed to the second mixer stage, where it is again heterodyned to produce a difference frequency or IF of zero frequency.

This selected component is then passed to the meter amplifier and detector circuit through an active filter having a controlled band-width. The meter detector output can then be read off on a db-calibrated scale, or may be applied to a secondary device such as a recorder.

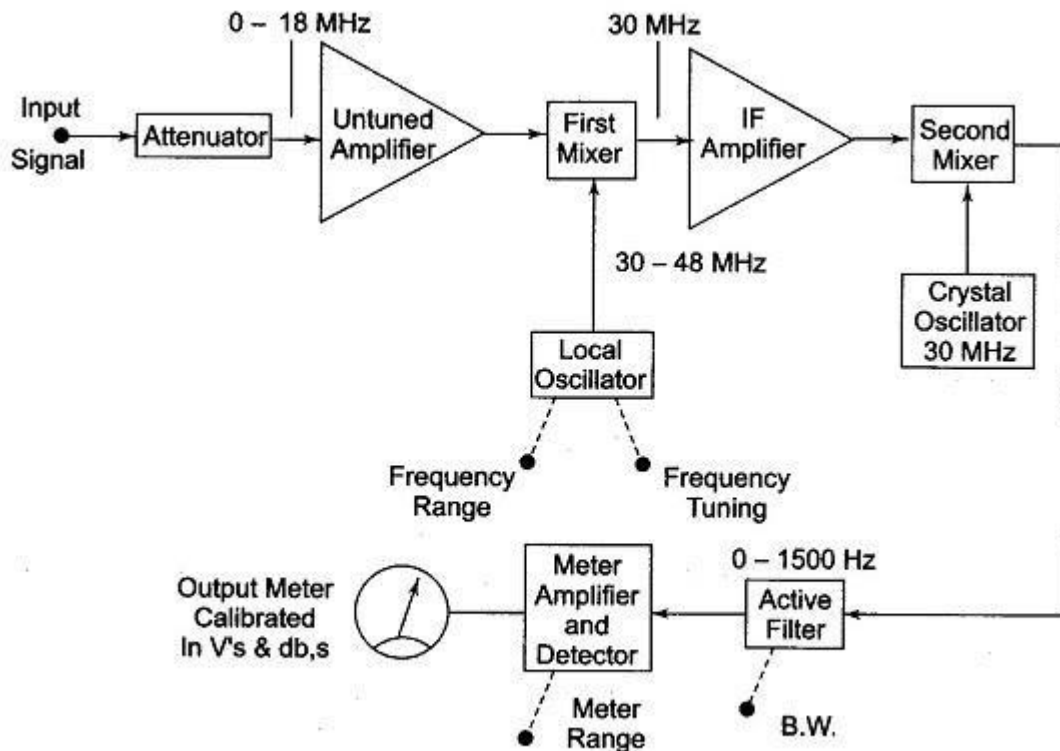

Fig. 9.4 RF Heterodyne Wave Analyzer

This wave analyzer is operated in the RF range of 10 kHz — 18 MHz, with 18 overlapping bands selected by the frequency range control of the local oscillator. The bandwidth, which is controlled by the active filter, can be selected at 200 Hz, 1 kHz and 3 kHz.

Frequency Selective Wave Analyzer:

The Frequency Selective Wave Analyzer consists of a very narrow pass-band filter section which can be tuned to a particular frequency within the audible frequency range (20 Hz — 20 kHz). The block diagram of a wave analyzer is as shown in Fig. 9.1(b).

The complex wave to be analyzed is passed through an adjustable attenuator which serves as a range multiplier and permits a larger range of signal amplitudes to be analyzed without loading the amplifier.

The output of the attenuator is then fed to a selective amplifier, which amplifies the selected frequency. The driver amplifier applies the attenuated input signal to a high-Q active filter. This high-Q filter is a low pass filter which allows the frequency which is selected to pass and reject all others. The magnitude of this selected frequency is indicated by the meter and the filter section identifies the frequency of the component. The filter circuit consists of a cascaded RC resonant circuit and amplifiers. For selecting the frequency range, the capacitors generally used are of the closed tolerance polystyrene type and the resistances used are precision potentiometers. The capacitors are used for range changing and the potentiometer is used to change the frequency

within the selected pass-band, Hence this wave analyzer is also called a Frequency selective voltmeter.

WWW.EEUGUIDE.COM

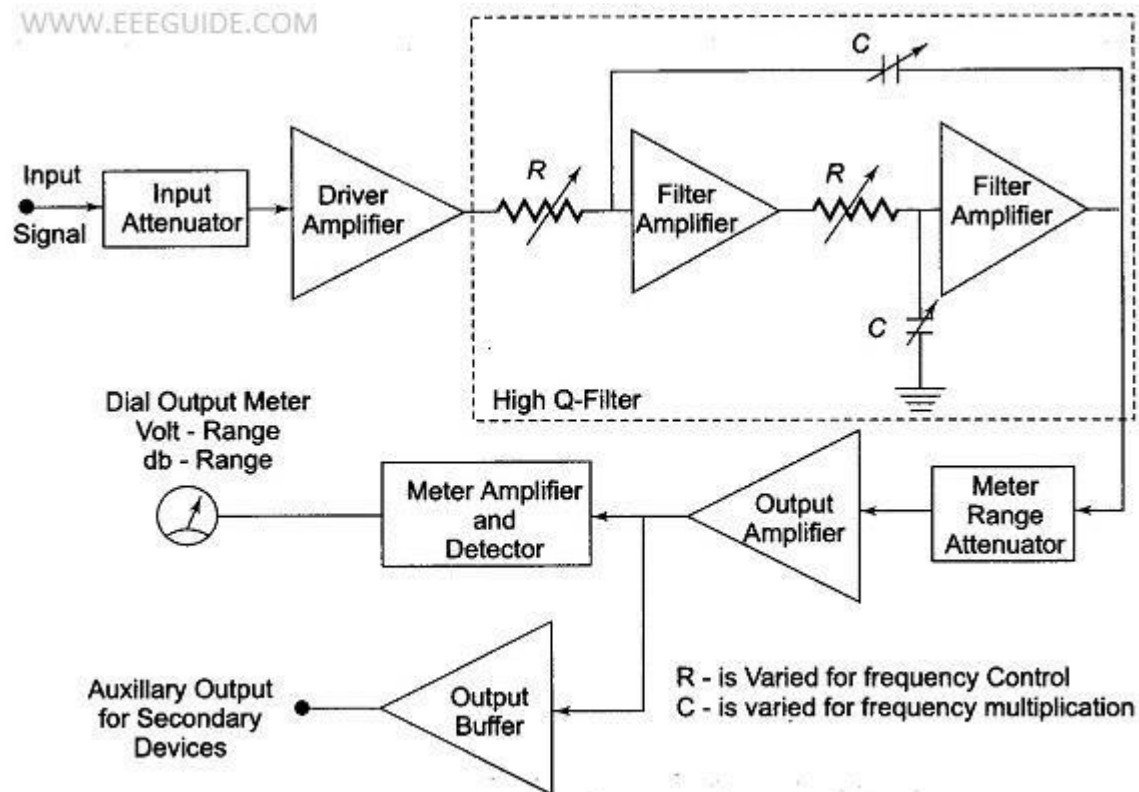

Fig. 9.1 (b) Frequency Selective Wave Analyzer

The complex wave to be analyzed is passed through an adjustable attenuator which serves as a range multiplier and permits a larger range of signal amplitudes to be analyzed without loading the amplifier.

The output of the attenuator is then fed to a selective amplifier, which amplifies the selected frequency. The driver amplifier applies the attenuated input signal to a high-Q active filter. This high-Q filter is a low pass filter which allows the frequency which is selected to pass and reject all others. The magnitude of this selected frequency is indicated by the meter and the filter section identifies the frequency of the component. The filter circuit consists of a cascaded RC resonant circuit and amplifiers. For selecting the frequency range, the capacitors generally used are of the closed tolerance polystyrene type and the resistances used are precision potentiometers. The capacitors are used for range changing and the potentiometer is used to change the frequency within the selected pass-band, Hence this wave analyzer is also called a Frequency selective voltmeter.

The entire AF range is covered in decade steps by switching capacitors in the RC section.

The selected signal output from the final amplifier stage is applied to the meter circuit and to an untuned buffer amplifier. The main function of the buffer amplifier is to drive output devices, such as recorders or electronics counters.

The meter has several voltage ranges as well as decibel scales marked on it. It is driven by an average reading rectifier type detector.

The wave analyzer must have extremely low input distortion, undetectable by the analyzer itself. The bandwidth of the instrument is very narrow, typically about 1% of the selective band given by the following response characteristics. (Fig. 9.2).

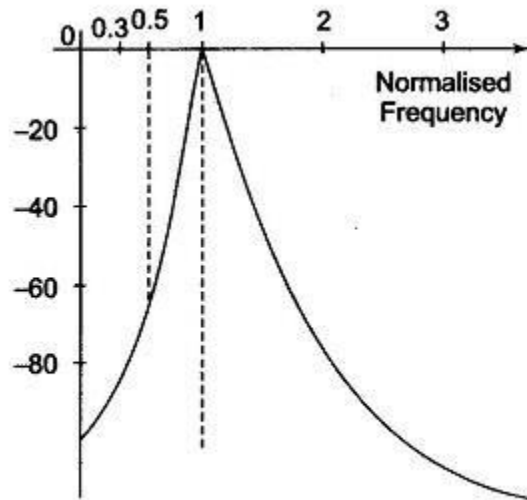

Fig. 9.2 Relative Response in dBs

Harmonic Distortion Analyzer:

Introduction: Harmonic distortion analyzers measure the total harmonic content in the waveforms. It can be shown mathematically that an amplitude distorted sine wave is made up of pure sine wave components, including the fundamental frequency of the input signal, and harmonic multiples of the fundamental frequency, 2f, 3f, 4f etc.

Harmonic distortion can be quantitatively measured very accurately with a harmonic distortion analyzer, generally called a distortion analyzer.

The total harmonic distortion or factor is given by

$$D = \sqrt{D_2^2 + D_3^2 + D_4^2 \dots}$$

where D_2, D_3, \dots represent the second harmonic, third harmonic, etc. respectively.

The distortion analyzer measures the total harmonic distortion without indicating the amplitude and frequency of each component waves.

Harmonic Distortion Analyzer:

A Harmonic Distortion Analyzer measures the total harmonic power present in the test wave rather than the distortion caused by each component. The simplest method is to suppress the fundamental frequency by means of a high pass filter whose cut off frequency is a little above the fundamental frequency. This high pass allows only the harmonics to pass and the total harmonic distortion can

then be measured. Other types of Harmonic Distortion Analyzer based on fundamental suppression are as follows.

1. Resonance Bridge

The bridge shown in Fig. 9.5 is balanced for the fundamental frequency, i.e. L and C are tuned to the fundamental frequency. The bridge is unbalanced for the harmonics, i.e. only harmonic power will be available at the output terminal and can be measured. If the fundamental frequency is changed, the bridge must be balanced again. If L and C are fixed components, then this method is suitable only when the test wave has a fixed frequency. Indicators can be thermocouples or square law VTVMs. This indicates the rms value of all harmonics. When a continuous adjustment of the fundamental frequency is desired, a Wien bridge arrangement is used as shown in Fig. 9.6.

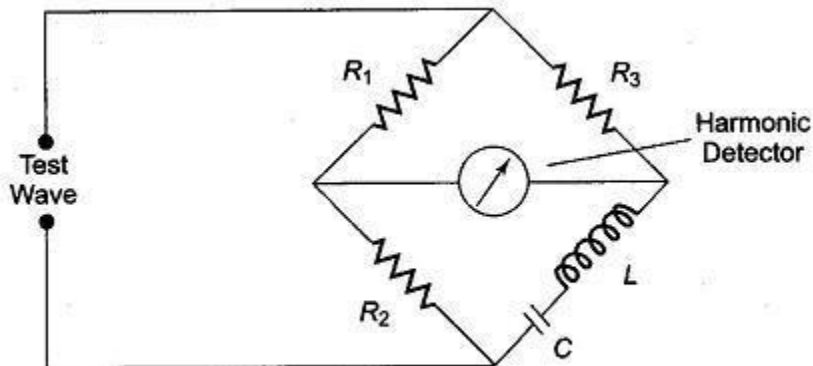

Fig. 9.5 Resonance Bridge

2. Wien's Bridge Method

The bridge is balanced for the fundamental frequency. The fundamental energy is dissipated in the bridge circuit elements. Only the harmonic components reach the output terminals. The harmonic distortion output can then be measured with a meter. For balance at the fundamental frequency, $C_1, C_2, C, R_1 = R_2 = R, R_3 = 2R_4$.

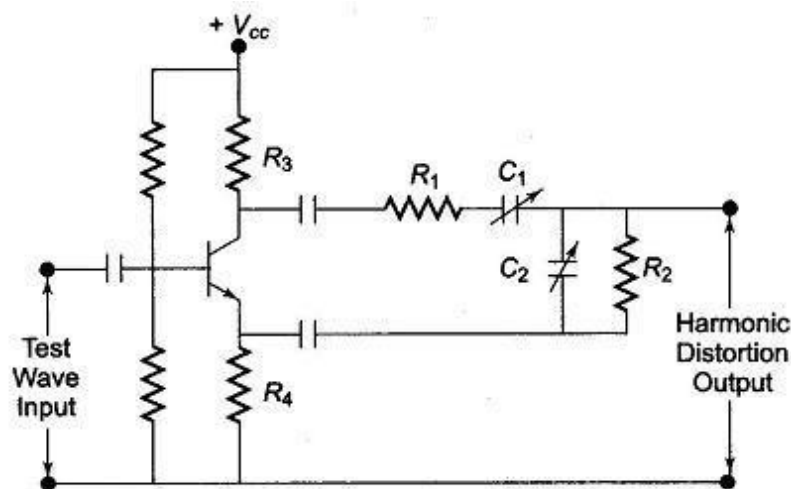

Fig. 9.6 Wien's Bridge Method

3. Bridged T-Network Method

Referring to Fig. 9.7 the, L and C 's are tuned to the fundamental frequency, and R is adjusted to bypass fundamental frequency. The tank circuit being tuned to the fundamental frequency, the fundamental energy will circulate in the tank and is bypassed by the resistance. Only harmonic components will reach the output terminals and the distorted output can be measured by the meter. The Q of the resonant circuit must be at least 3-5.

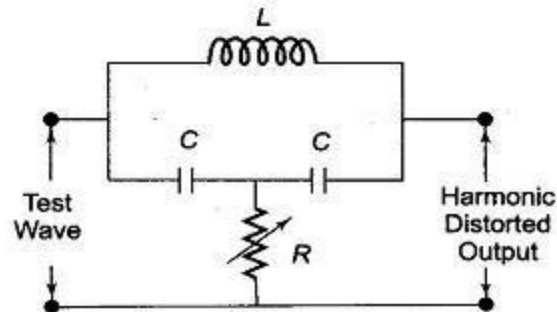

Fig. 9.7 Bridged T-Network Method

One way of using a bridge T-network is given in Fig. 9.8.

The switch S is first connected to point A so that the attenuator is excluded and the bridge T-network is adjusted for full suppression of the fundamental frequency, i.e. minimum output. Minimum output indicates that the bridged T-network is tuned to the fundamental frequency and that the fundamental frequency is fully suppressed.

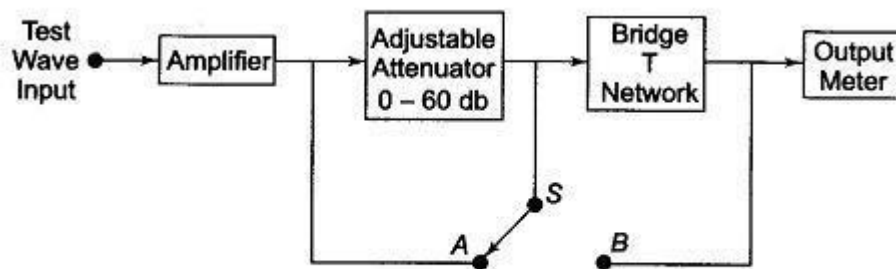

Fig. 9.8 Harmonic Distortion Analyzer Using Bridged T-Network

The switch is next connected to terminal B , i.e. the bridged T-network is excluded. Attenuation is adjusted until the same reading is obtained on the meter. The attenuator reading indicates the total rms distortion. Distortion measurement can also be obtained by means of a wave analyzer, knowing the amplitude and the frequency of each component, the Harmonic Distortion Analyzer can be calculated. However, distortion meters based on fundamental suppression are simpler to design and less expensive than wave analyzers. The disadvantage is that they give only the total distortion and not the amplitude of individual distortion components.

Spectrum Analyzer Block Diagram:

Spectrum Analyzer Block Diagram – The most common way of observing signals is to display them on an oscilloscope, with time as the X -axis (i.e. amplitude of the signal versus time). This is

the time domain. It is also useful to display signals in the frequency domain. The instrument providing this frequency domain view is the spectrum analyzer.

A Spectrum Analyzer Block Diagram provides a calibrated graphical display on its CRT, with frequency on the horizontal axis and amplitude (voltage) on the vertical axis.

Displayed as vertical lines against these coordinates are sinusoidal components of which the input signal is composed. The height represents the absolute magnitude, and the horizontal location represents the frequency.

These instruments provide a display of the frequency spectrum over a given frequency band. Spectrum analyzers use either a parallel filter bank or a swept frequency technique.

In a parallel filter bank analyzer, the frequency range is covered by a series of filters whose central frequencies and bandwidth are so selected that they overlap each other, as shown in Fig. 9.9(a).

Typically, an audio analyzer will have 32 of these filters, each covering one third of an octave.

For wide band narrow resolution analysis, particularly at RF or microwave signals, the swept technique is preferred.

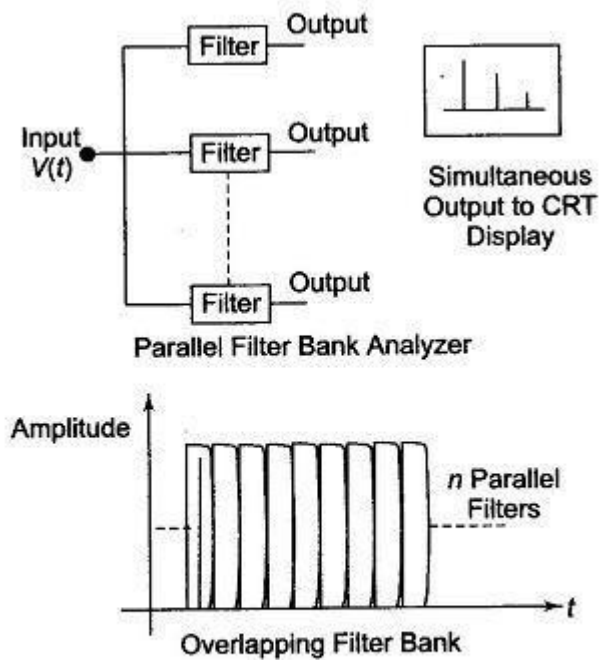

Fig. 9.9 (a) Spectrum Analyzer (Parallel Filter Bank Analyzer)

Basic Spectrum Analyzer Using Swept Receiver Design

Referring to the block diagram of Fig. 9.9(b), the sawtooth generator provides the sawtooth voltage which drives the horizontal axis element of the scope and this sawtooth voltage is frequency controlled element of the voltage tuned oscillator. As the oscillator sweeps from f_{min} to f_{max} of

its frequency band at a linear recurring rate, it beats with the frequency component of the input signal and produces an IF, whenever a frequency component is met during its sweep. The frequency component and voltage tuned oscillator frequency beats together to produce a difference frequency, i.e. IF. The IF corresponding to the component is amplified and detected if necessary, and then applied to the vertical plates of the CRO, producing a display of amplitude versus frequency.

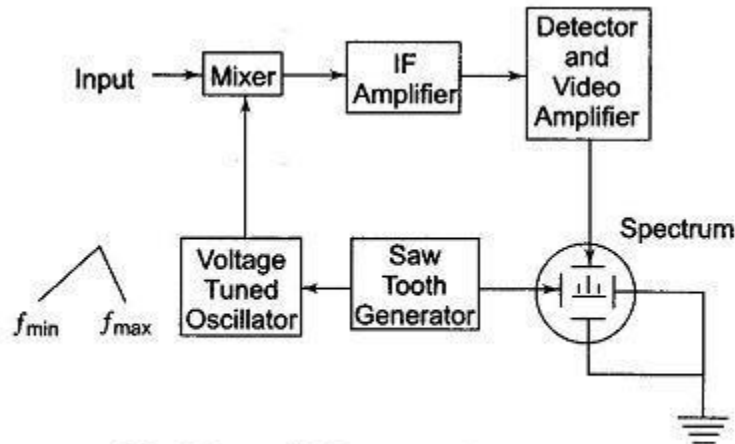

Fig. 9.9 (b) Spectrum Analyzer

The spectrum produced if the input wave is a single toned A.M. is given in Figs 9.10, 9.11, and 9.12.

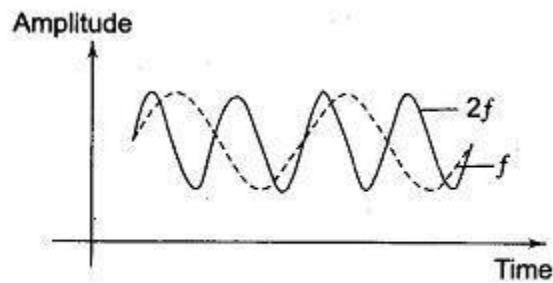

Fig. 9.10 Test Wave Seen on Ordinary CRO

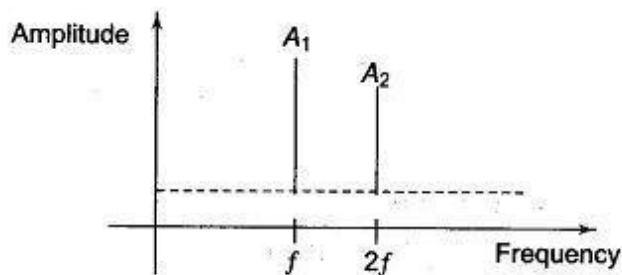

Fig. 9.11 Display on the Spectrum CRO

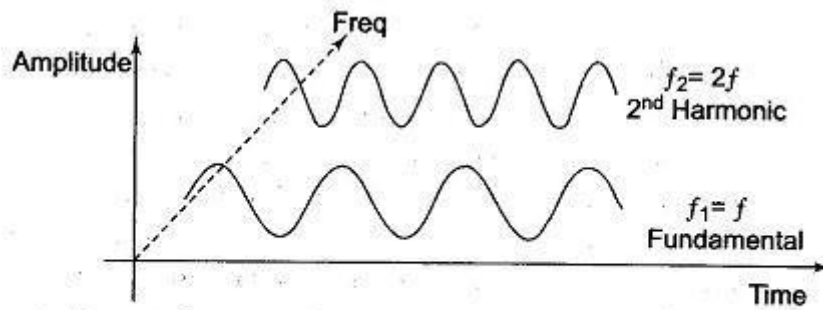

Fig. 9.12 Test Waveform as Seen on X-Axis (Time) and Z-Axis (Frequency)

Spectrum Analyzer Applications

One of the principal applications of spectrum analyzers has been in the study of the RF spectrum produced in microwave instruments. In a microwave instrument, the horizontal axis displays a wide range as 2 — 3 GHz for a broad survey and as narrow as 30 kHz, for a highly magnified view of any small portion of the spectrum. Signals at microwave frequency separated by only a few kHz can be seen individually.

The frequency range covered by this instrument is from 1 MHz to 40 GHz. The basic block diagram (Fig. 9.13) is of a spectrum analyzer covering the range 500 kHz to 1 GHz, which is representative of a superheterodyne type.

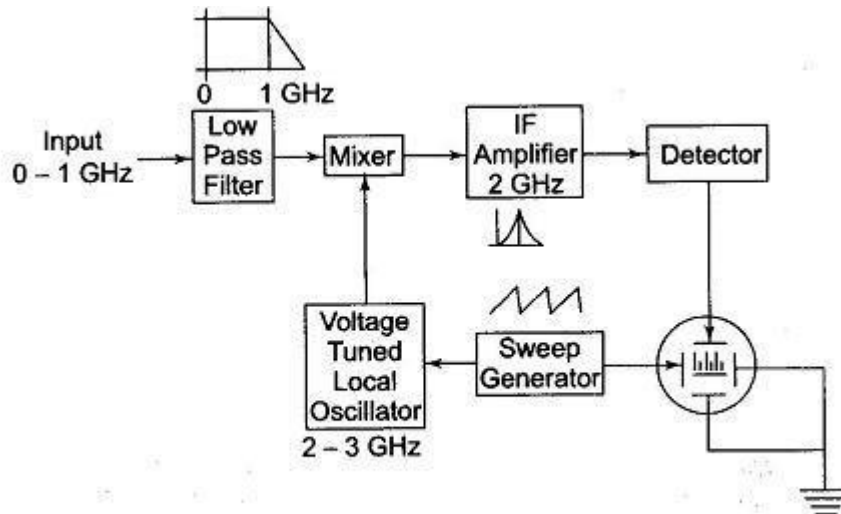

Fig. 9.13 RF Spectrum Analyzer

The input signal is fed into a mixer which is driven by a local oscillator. This oscillator is linearly tunable electrically over the range 2 — 3 GHz. The mixer provides two signals at its output that are proportional in amplitude to the input signal but of frequencies which are the sum and difference of the input signal and local oscillator frequency.

The IF amplifier is tuned to a narrow band around 2 GHz, since the local oscillator is tuned over the range of 2 — 3 GHz, only inputs that are separated from the local oscillator frequency by 2 GHz will be converted to IF frequency band, pass through the IF frequency amplifier, get rectified and produce a vertical deflection on the CRT.

From this, it is observed that as the sawtooth signals sweep, the local oscillator also sweeps linearly from 2 — 3 GHz. The tuning of the spectrum analyzer is as swept receiver, which sweeps linearly from 0 to 1 GHz. The sawtooth scanning signal is also applied to the horizontal plates of the CRT to form the frequency axis. (The Spectrum Analyzer Block Diagram is also sensitive to signals from 4 — 5 GHz referred to as the image frequency of the superheterodyne. A low pass filter with a cut off frequency above 1 GHz at the input suppresses these spurious signals.) Spectrum analyzers are widely used in radars, oceanography, and bio-medical fields.

Digital Fourier Analyzer:

The basic principle of a Digital Fourier Analyzer is shown in Fig. 9.14. The Digital Fourier Analyzer converts the analogue waveform over time period T into N samples.

The discrete spectral response $S_x(k\Delta f); k=1,2,\dots,N$ which is equivalent to simultaneously obtaining the output from N filters having a bandwidth given by $\Delta f=1/T$, is obtained by applying a Discrete Fourier Transform (DFT) to the sampled version of the signal. The spectral response is thus given by

$$S_x(k\Delta f) = \frac{T}{N} \sum_{n=1}^N x(n \cdot \Delta t) \exp\left(\frac{-j2\pi kn}{N}\right)$$

where $k=1,2,3,\dots,N$.

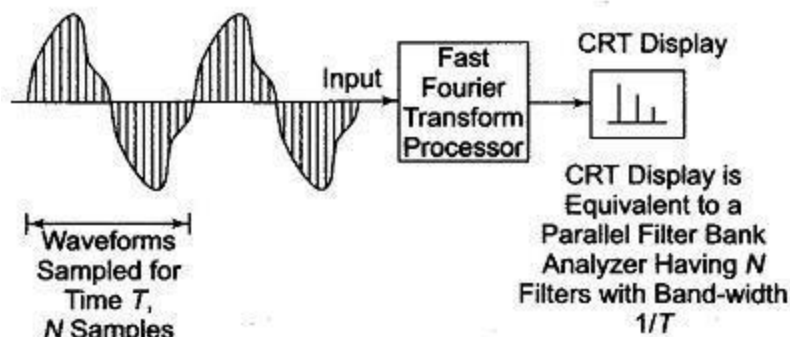

Fig. 9.14 Basic of a Digital Fourier Analyzer

$S_x(k\Delta f)$ is a complex quantity, which is obtained by operating on all the sample $x(n \cdot \Delta t); n=1,2,3,\dots,N$ by the complex factor $\exp[-j[(2\pi kn)/N]]$.

The discrete inverse transform is given by

$$x(n \cdot \Delta t) = \frac{N}{T} \sum_{k=1}^N S_x(k \cdot \Delta f) \exp\left(\frac{j2\pi kn}{N}\right)$$

where $n=1,2, \dots, N$.

Since $S_x(k, \Delta f); k=1, 2, \dots, N$ is a complex quantity, the DFT provides both amplitude and phase information at a particular point in the spectrum.

The discrete transforms are usually implemented by means of the Fast Fourier Transform (FFT), which is particularly suitable for implementation in a digital computer, since N is constrained to the power of 2, i.e. $2^{10} = 1024$.

A digital signal analyzer block diagram is shown in Fig. 9.15. This digital signal analyzer employs an FFT algorithm.

The block diagram is divided into three sections, namely the input section, the control section and the display section.

The input section consists of two identical channels. The input signal is applied to the input amplifier, where it is conditioned and passed through two more anti-aliasing filters. The cut-off frequencies of these filters are selected with respect to the sampling frequency being used. The 30 kHz filter is used with a sampling rate of 102.4 kHz and the 300 kHz filter with a sampling rate of 1.024 MHz.

To convert the signal into digital form, a 12 bit ADC is used. The output from the ADC is connected to a multiplier and a digital filter.

Depending on the mode of the analyzer to be used, either in Base-band mode (in which the spectrum is displayed from a dc to an upper frequency within the bandwidth of the analyzer) or in the band-selectable mode (which allows the full resolution of the analyzer to be focused in a narrow frequency band), the signal is multiplied either by a sine or cosine function.

The processing section of the analyzer provides FFT processing on the input signal (linear or logarithm).

For one channel this can provide the real (magnitude) and imaginary (phase) of the linear spectrum $S_x(f)$ of a time domain signal

$$S_x(f) = F(x(t))$$

where $F(x(t))$ is the Fourier transform of $x(t)$. The autospectrum $G_{xx}(f)$ which contains no phase information is obtained from $S_x(f)$ as where $S_x(f)^*$ indicates the complex conjugate of $S_x(f)$.

$$G_{xx}(f) = S_x(f) S_x(f)^*$$

The Power Spectral Density (PSD) is obtained by normalizing the function $G_{xx}(f)$ to a bandwidth of 1 Hz, which represents the power in a bandwidth of 1 Hz centered around the frequency f

The Inverse Fourier Transform of $G_{xx}(f)$ is given by

$$R_{xx}(\tau) = F^{-1}(G_{xx}(f))$$

$$R_{xx}(\tau) = F^{-1}(S_x(f) S_x(f)^*)$$

writing the above equation in terms of the time domain characteristics of the signal $x(t)$, its autocorrelation function is defined as

$$R_{xx}(\tau) = \lim_{T \rightarrow \infty} \frac{1}{T} \int_0^T x(t) x(t + \tau) dt$$

By the use of two channels, the combined properties of the two signals can be obtained. The cross-power spectrum of the two signals $x(t)$ and $y(t)$ can be computed as

$$G_{yx}(f) = S_y(f) S_x^*(f)$$

where $S_y(f)$ is the linear spectrum of $y(t)$ and $S_x^*(f)$ is the complex conjugate spectrum of $x(t)$.

If $x(t)$ represents the input to a system and $y(t)$ the output of the system, then its transfer function $H(f)$, which contains both amplitude and phase information can be obtained by computing

$$H(f) = \frac{G_{yx}(f)}{G_{xx}(f)}$$

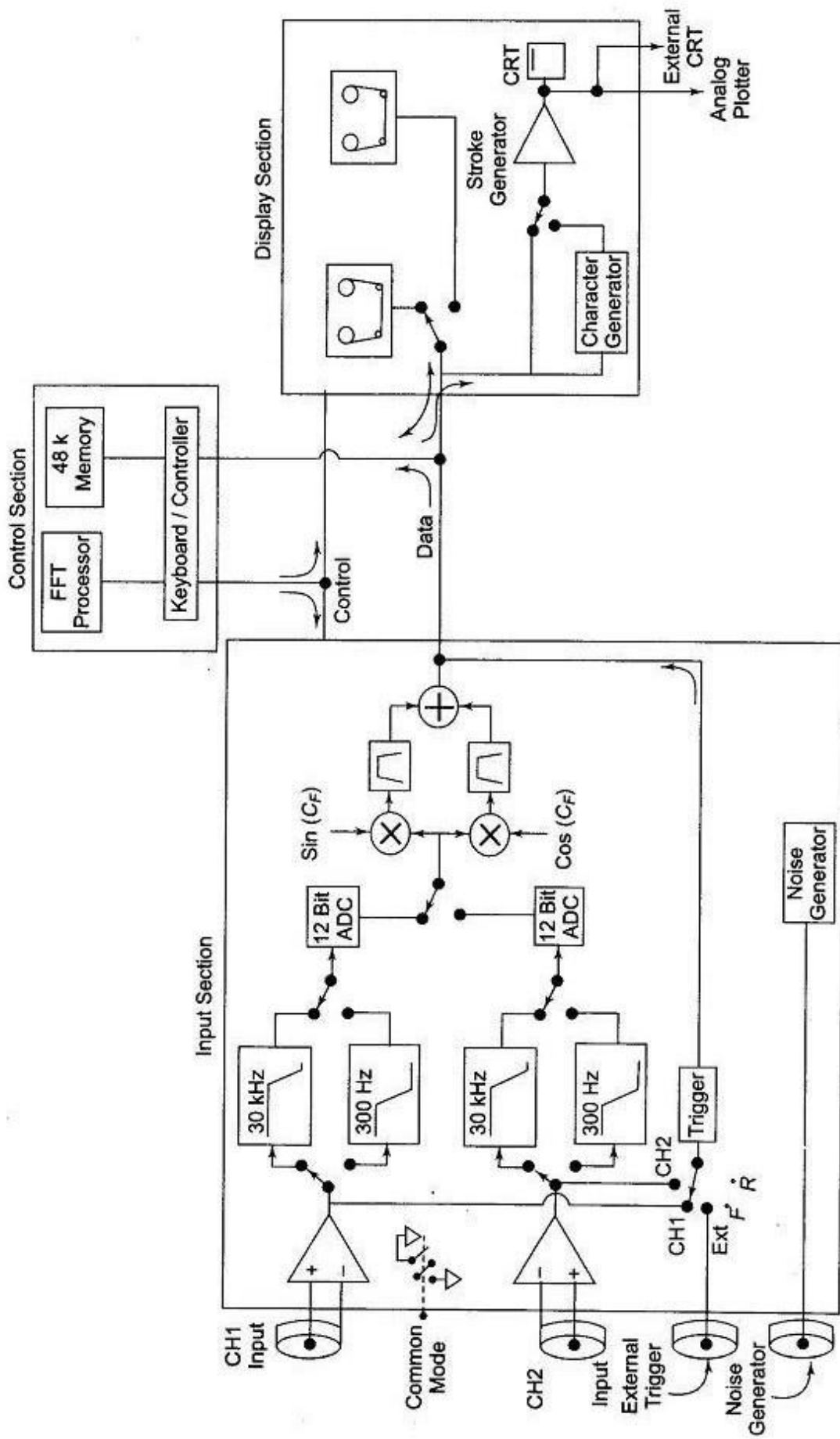

Fig. 9.15 Block Diagram of a Digital Signal Analyzer